

## Instruction Manual

# Terranova Model 926A Dual Convection Gauge Controller

for use with MKS/HPS Type 317 Convection or  
Granville-Phillips CONVECTRON® Vacuum Gauges

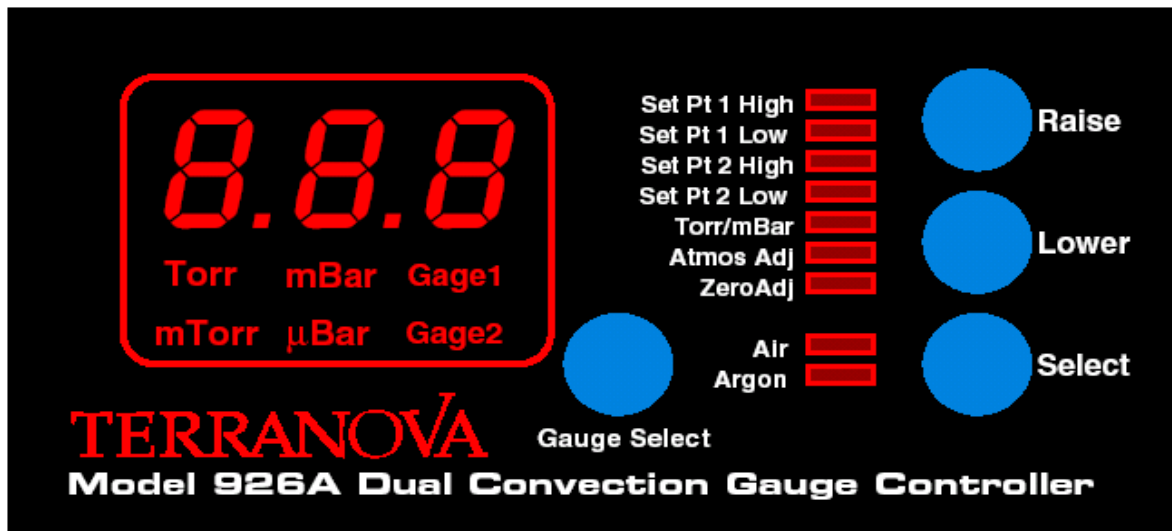

rev071404sr

Copyright © 2002 by Duniway Stockroom Corp.

## Table of Contents

---

<b>I</b>	<b>Safety Information</b>	<b>page 4</b>
<b>II</b>	<b>Front Panel, Rear Panel &amp; Dimensions</b>	<b>page 5</b>
<b>III</b>	<b>Overview</b>	<b>page 7</b>
	<b>A. General Description</b>	
	<b>B. Specifications</b>	
<b>IV</b>	<b>Installation</b>	<b>page 10</b>
	<b>A. Unpack the Controller</b>	
	<b>B. Mount the Controller</b>	
	<b>C. Select the Gauge Tube</b>	
	<b>D. Connect the Gauge Tube</b>	
	<b>E. Attach the Gauge Cable</b>	
	<b>F. Make Relay Connections</b>	
	<b>G. Make Accessory Connections</b>	
	<b>H. Check Supply Voltage</b>	
	<b>I. Attach the Power Cord</b>	
<b>V</b>	<b>Operation</b>	<b>page 14</b>
	<b>A. Turn Power On</b>	
	<b>B. Front Panel Controls</b>	
	<b>C. Set Point Operation</b>	
	<b>D. Reading Pressure</b>	
	<b>E. Analog Output</b>	
	<b>F. Serial Interface</b>	

<b>VI</b>	<b>Maintenance</b>	<b>page 24</b>
	<b>A. Changing Fuses</b>	
	<b>B. Schematic Diagrams</b>	
<b>VII</b>	<b>Troubleshooting</b>	<b>page 25</b>
<b>VIII</b>	<b>Return Procedure</b>	<b>page 27</b>
<b>IX</b>	<b>Warranty</b>	<b>page 28</b>
<b>X</b>	<b>Statement of Conformity</b>	<b>page 29</b>

### **List of Figures**

---

<b>Figure 1:</b>	<b>Model 926A front view</b>	<b>page 5</b>
<b>Figure 2:</b>	<b>Model 926A rear view</b>	<b>page 5</b>
<b>Figure 3</b>	<b>Model 926A Dimensions</b>	<b>page 6</b>
<b>Figure 4:</b>	<b>Terranova 926A - Sensor Connector Pins</b>	<b>page 12</b>
<b>Figure 5:</b>	<b>Accessory Connector Pins</b>	<b>page 13</b>
<b>Figure 6:</b>	<b>Analog Output versus Displayed Pressure</b>	<b>page 18</b>
<b>Figure 7:</b>	<b>Pressure versus Analog Output</b>	<b>page 19</b>
<b>Figure 8:</b>	<b>Serial Output Format versus Pressure</b>	<b>page 20</b>
<b>Figure 9:</b>	<b>Indicated pressure on Model 926A display, torr</b>	<b>page 22</b>
<b>Figure 10:</b>	<b>MKS/HPS Model 317 CEP Sensor Pins</b>	<b>page 25</b>

## I Safety Information

### Explosive Gases

**WARNING!**

Do not use the Model 926A Dual Convection Gauge Controller to measure the pressure of combustible gas mixtures. The gauge normally operates at low temperatures, but it is possible that momentary transients or controller malfunction may cause ignition of combustible mixtures, which then might explode and cause damage to equipment and injury to personnel.

### Limitation on use of Compression Mounts

**WARNING!**

Do not use a compression mount (quick-connect) for attaching the gauge tube to the vacuum system in applications that may develop positive pressures. Positive pressures may cause the tube to be blown out of a compression fitting and damage equipment and injure personnel.

### Chemicals

**WARNING**

Many organic cleaning solvents, such as acetone, produce fumes that are toxic or flammable. Use such solvents only in areas that are well ventilated to the outdoors and away from electronic equipment, open flames, or other potential ignition sources.

### Please let us Know...

Terranova products are the most advanced instruments of their type available from any manufacturer. We have made this Instruction Manual as complete and clear as possible. Let us know if you have any comments that can make this manual or our products more useful.



## II Front Panel, Rear Panel & Dimensions

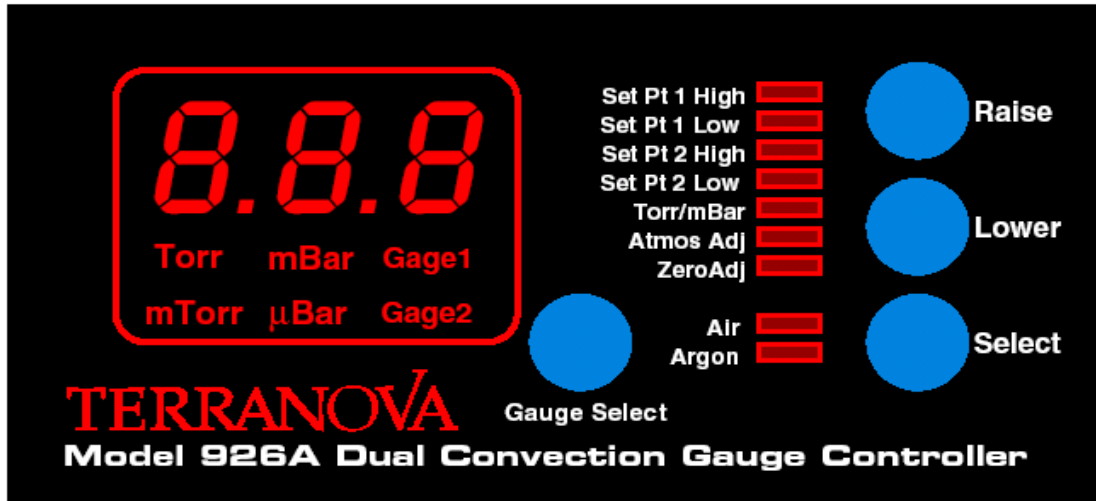

Figure 1: Model 926A front view

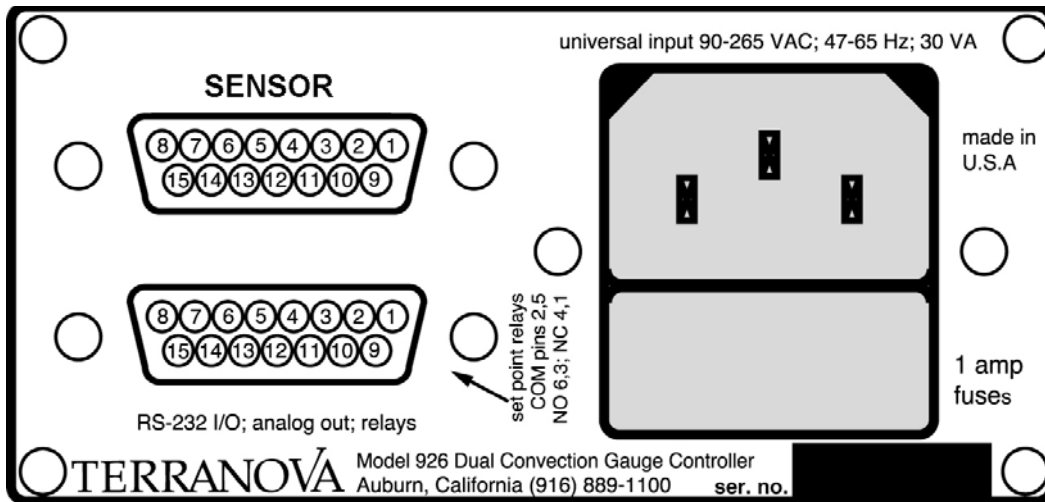
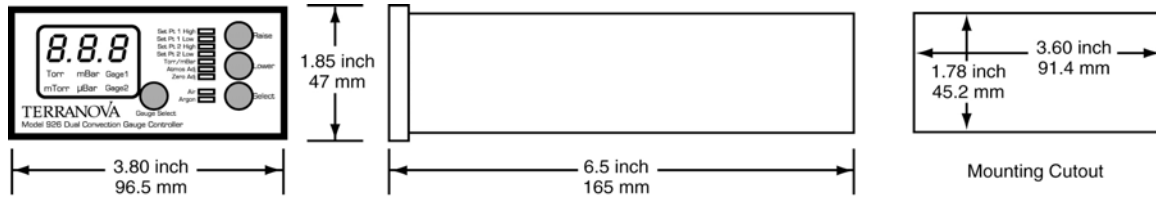

Figure 2: Model 926A rear view



**Figure 3: Model 926A Dimensions**

## III

## Overview

### C. General Description

The Terranova Scientific Model 926A Dual Convection Gauge Controller displays vacuum pressure as measured from a Granville-Phillips CONVECTRON® gauge tube or a HPS/MKS Type 317 Convection Enhanced Pirani gauge tube. It displays vacuum measurements based on thermal conductivity of air/nitrogen or argon. The Model 926A controller covers the range from 0.1 mTorr to 1000 Torr or 0.1  $\mu$ bar to 1000 mBar, and controls two relays with independent set points.

The primary addition which separates the Terranova 926A from the earlier Terranova 926 is the opportunity for the user to choose between response curves for the chosen Convection sensor tube. (HPS/MKS Model 317 CEP or Granville-Phillips Model 275 Convector.) This gives the user increased accuracy.

### D. Specifications

#### 1. Useful Measuring Range

0.1 mTorr ( $\mu$ bar) to 995 Torr (mBar), for air or nitrogen; ( $10^{-4}$  torr (mBar) to  $10^3$  torr (mBar)); range selection is automatic

#### 2. Display Range

-19 mTorr ( $\mu$ bar) to 995 torr (mBar); pressures lower than -19 mTorr ( $\mu$ bar) display **LO**; pressures higher than 995 torr (mBar) or no tube attached, display **HI**; if cable is not connected to the unit, display shows **OFF**.

#### 3. Accuracy of Interface to Gauge

Pressure calculation algorithm is accurate to  $\pm 1\%$  of published data for the HPS/MKS Model 317 CEP or the Granville-Phillips CONVECTRON® 275 gauge (this is for the 926A controller only, and does not include uncertainty of the CONVECTRON® gauge).

#### 4. Units of Display

torr or mBar; user selectable

#### 5. Vacuum Gauge

The Terranova 926A will operate either the HPS/MKS Model 317 Convection Enhanced Pirani (CEP) or Granville-Phillips CONVECTRON® MODEL 275 (275) gauges. User choice of response curves for CEP or 275 and for AIR or ARGON.

#### 6. Operating Temperature Range

+2 to +50 deg. Celsius

**7. Pressure Display**

3-digit bright red LED, 10 mm high

**8. Display Indicators**

red LED for set points and other parameters

**9. Display Resolution**

varies; from 0.1 mTorr ( $\mu$ bar) below 10 mTorr ( $\mu$ bar), to 5 Torr (mBar) above 100 Torr (mBar)

**10. VAC and ATM Adjust**

adjusted by front panel push-button

**11. Process Control Set Points**

two, adjusted by front panel push-button

**12. Process Control Relays**

two relays, 2 amp, 240 VAC contacts; independent Normally Open and Normally Closed; +5 volts is provided for TTL applications; available through the D15 accessory connector

**13. Nonvolatile Memory**

for VAC, ATM and SET POINTS

**14. Analog Output**

calibrated, 12-bit resolution, logarithmic, 0.50 volts/decade; 0.0 mTorr ( $\mu$ bar) = 0 volts; 10 mTorr ( $\mu$ bar) = 0.50 volts; 100 mTorr ( $\mu$ bar) = 1.00 volts; etc.; available through the D15 accessory connector

**15. RS-232 Input/Output**

allows user to read pressure and set points; 9600 baud, 8-N-1; available through the D15 accessory connector

**16. Operating Voltage**

the Model 926A has a universal power supply, which operates on input voltages from 85 VAC to 265 VAC 50/60 Hz; standard IEC 320 instrument power input receptacle on rear panel; replacement fuse type: 5 mm X 20 mm, regular 1 amp

manufacturer

Bussman

Littlefuse

fuse type

GDB-1A or GDC-1A

217 001 or 218 001

**17. Weight**

1 lb. / 0.5 kg





**18. Mounting**

Side clips are provided for panel mounting in standard 1/8 DIN cutout.

**19. Environmental Considerations**

not for use with explosive or corrosive gases

**20. Vacuum gauge tube:**

the HPS/MKS Model 317 gauge and the Granville-Phillips CONVECTRON® gauge series 275 are available from Duniway Stockroom or the manufacturers listed below:

**Duniway Stockroom**  
1305 Space Park Way  
Mountain View, CA 94043  
Telephone: (800) 446-8811 or (650) 969-8811  
Facsimile: (650) 965-0764  
Internet: [www.duniway.com](http://www.duniway.com)

**HPS Division, MKS Instruments, Inc.**  
5530 Sterling Drive  
Boulder, CO 80301  
Telephone: (800) 367-1967 or (303) 449-9861  
Facsimile: (303) 442-6880

**Granville-Phillips Company**  
5675 Arapahoe Avenue  
Boulder, CO 80303  
Telephone: (800) 776-6543 or (303) 443-7660  
Facsimile: (303) 443-2546

## IV Installation

### A. Unpack the Controller

Carefully unpack the Model 926A Convection Gauge Controller. The shipment includes these components:

- controller unit
- power cord
- mounting clips
- D15 accessory connector
- this instruction manual

If your controller does not have all of these items, call Duniway Stockroom. If it appears to have been damaged in shipment, contact the shipper.

### B. Mount the Controller

You can mount the controller unit freestanding on a bench, table top, or shelf, or you can mount it in a rack or cabinet. The controller unit is housed in a standard 1/8 DIN box.

If you are mounting the unit in a panel, the cutout dimensions are 45.2 mm by 91.4 mm (See page 6). One mounting clip attaches to each of the sides of the controller unit. To attach the clip, slide the beveled surfaces of the clip under the cutout on the side of the box and push the clip toward the back of the unit until the central tongue locks the clip in place. Then slide the unit into the panel; the clips will hold the unit in place.

Be sure to leave enough clearance at the back of the controller unit for easy access to cable connections.

### C. Select the Gauge Tube

The Model 926A controller is designed to work with the HPS/MKS Model 317 and Granville-Phillips CONVECTRON® gauge tubes, series 275. See **Specifications** for availability of gauges. If you have difficulty obtaining a gauge, please contact us at Duniway Stockroom.

#### CAUTION

**Use of a gauge tube other than those listed above may cause improper readings, and may cause damage to the gauge tube.**

## D. Connect the Gauge Tube

Make sure that the gauge tube is securely connected to the vacuum system, using good vacuum practice. The gauge tube must be mounted with its axis horizontal, and the port pointing down; large errors may result at higher pressures if the gauge axis is not horizontal.

## E. Attach the Gauge Cable

The CONVECTRON® gauge cable has a special socket for the gauge on one end and a 15-pin D-sub connector on the other; the cable uses standard Granville-Phillips pin assignment for both ends of the cable. For the HPS/MKS Model 317 gauge tube, the gauge cable has a 9-pin D-sub connector for the gauge on one end and a 15-pin D-sub connector on the other end. See the table below for pin connection information.

### CAUTION

**Make sure that the power to the controller unit is off before you connect the gauge tube to the controller unit. Unplugging and then plugging in the gauge cable with the power on can cause the HPS/MKS or Granville-Phillips gauge to burn out.**

**For the HPS/MKS tube, connect the 9-pin D-sub connector to the matching connector on the tube. For the CONVECTRON®, align the keyway of the connector with the key on the gauge tube, and push the connector onto the gauge tube's pins until it seats firmly.**

**Connect the 15-pin D-sub plug of the gauge cable to the 15-pin D-sub jack on the back of the controller unit. Push the plug onto the jack until it is firmly in place. Tighten the retaining screws to make certain the connector remains in place. Loose connections can damage the gauge tubes.**

*NOTE*

If you have a cable from one of the analog display Granville-Phillips CONVECTRON® gauge controllers, it is an easy task to convert the cable for use with the Model 926A. The analog controller uses a combination cable for the CONVECTRON® gauge and for AC power input. To convert the cable:

- You must have a D15 connector with male pins; a connector with solder cups is an easy version to work with. If you have difficulty locating one of these, call us and we will send you one.
- Identify the cable which plugs into the CONVECTRON® gauge.
- Follow the cable to the edge-connector and cut the cable, separating the cable from the edge-connector.
- Remove the jacket of the cable, about 1.5 inch (40 mm).
- Strip the wires, about 0.25 inch (0.5 mm).
- Observe the pin numbers identified on the CONVECTRON® gauge connector and the D15 connector.
- Connect as follows; you should verify the connections with a continuity checker:

<u>926A D15 connector</u>	<u>CONVECTRON® tube</u>	<u>HPS/MKS 317 tube D9</u>
pin 1	no connection	no connection
pin 2	ground	gauge 1, pins 2,4,5 & 9
pin 3	ground	gauge 1, pins 2,4,5 & 9
pin 4	no connection	gauge 1, pins 2,4,5.& 9
pin 5	gauge 1, pin 2	gauge 1, pin 7
pin 6	gauge 1, pin 5	gauge 1, pin 8
pin 7	gauge 1, pin 1	gauge 1, pins 1,3 & 6
pin 8	gauge 1, pin 1	gauge 1, pins 1,3 & 6
pin 9	ground	gauge 2, pins 2,4,5 & 9
pin 10	no connection	gauge 2, pins 2,4,5 & 9
pin 11	gauge 2, pin 2	gauge 2, pin 7
pin 12	gauge 2, pin 5	gauge 2, pin 8
pin 13	gauge 2, pin 1	gauge 2, pins 1,3 & 6
pin 14	gauge 2, pin 1	gauge 2, pins 1,3 & 6
pin 15	ground	gauge 2, pins 2,4,5 & 9

**Figure 4: Terranova 926A - Sensor Connector Pins**

**F. Make Relay Connections**

You can set two process control set points from the front panel of the controller (SET PT 1) and (SET PT 2). The set points control two relays that are accessible through the connector on the back of the controller. SET PT 1 controls relay #1, and SET PT 2 controls relay #2. Relay contacts are available through the D15 Accessory Connector. See pin connection table below. It is wise to use ‘snubbing’ components to avoid inductive-load-transients from damaging relay contacts.



## G. Make Accessory Connections

The 15-pin D-sub Accessory Connector is on the rear panel of the 926A, see fig. 2, page 6. The connector has female pins; the mating connector must have male pins. Mating D-sub 15 connectors are available from many of the normal electronic sources. If you need help identifying a source, please contact us.

Following are pin assignments for the Accessory Connector:

<u>15-pin</u>	<u>Accessory Connector</u>
pin 1	set point #1 relay, normally closed
pin 2	set point #1 relay, common
pin 3	set point #1 relay, normally open
pin 4	set point #2 relay, normally closed
pin 5	set point #2 relay, common
pin 6	set point #2 relay, normally open
pin 7	Tx, RS-232 signal out of the 926A; 9600-N-8-1
pin 8	Rx, RS-232 signal into the 926A
pin 9	ground, RS-232 and analog common
pin 10	no function
pin 11	no function
pin 12	no function
pin 13	analog output, 1K output, 0.5 volts/decade
pin 14	no function
pin 15	no function

**Figure 5: Accessory Connector Pins**

## H. Check Supply Voltage

The Model 926A incorporates a universal power supply. This allows the 926A to operate on any input voltage from 90 VAC to 265 VAC, 47 to 65 Hz.

## I. Attach the Power Cord

Plug the power cord into the receptacle in the power module on the rear of the 926A.

## V Operation

### A. Turn Power On

Plug the AC power end of the power cord into an electrical outlet. The loudspeaker will “beep” and test all indicators while the controller executes its self test. After being turned on, the instrument will go through the following sequence:

- “beeper”
- indicators for TORR, MTORR, MBar,  $\mu$ Bar, GAGE 1, GAGE 2
- 10 LED indicators for set points and other functions
- all three digits will light, including decimal points
- display shows the model number of the instrument, **926**
- display shows software version, e.g. **1.01**
- display shows gauge type response curve e.g. **275 or CEP**

The 926A will go into normal operation and begin measuring pressure. If a gauge cable is not connected to the 926A, the display will show **OFF**. If the system pressure is greater than 990 Torr (mBar) or if a gauge is not connected to the cable, the display will show **HI**.

### B. Choice of Model 317 HPS/MKS CEP or Model 275 Convectron<sup>®</sup> Response Curves

#### Default: G-P Model 275 Convectron<sup>®</sup> (“275”)

The “CEP” tube and the “275” tube have slightly different response curves over the 7 decades of pressure indication. In order to provide the most accurate pressure indication, the user is offered the choice of response curves, depending on the sensor tube chosen.

To change from “275” to “CEP” response curves, unplug the 926A from its power source. Press and hold RAISE and SELECT buttons at the same time; while holding the RAISE and SELECT buttons depressed, plug the power cord in. You will hear a few short ‘chirps’ from the loudspeaker confirming the response curve has been changed. The digital display will show **CEP** to confirm the reset has been entered. This process can be reversed by following the same procedure. The unit will be returned to the 275 response curve during Reset of Stored (Default) Values.

## C. Front Panel Controls

The Model 926A allows flexible configuration of operation using simple entry from the front panel buttons labeled GAUGE SELECT, SELECT, RAISE and LOWER. Parameters which you may adjust are selected by scrolling through the list which begins with SET PT 1 HIGH. Each time the SELECT button is pushed, the led indicator advances to the next parameter. The LED indicators will be lit to indicate which parameter is being adjusted, and the digital display will flash to indicate the value of the parameter being adjusted.

Each push of a button will give a short “beep” from the loudspeaker to confirm the button was pushed. If you have reached the limit of adjustment or if the button push is not allowed, the loudspeaker will give a long “beep”.

Following is detail description of the parameter selection and adjustment:

### 1. Set Pt 1 High

This sets the high limit of the set point. Above this pressure, the set point relay will be de-energized. Press the RAISE and LOWER buttons to enter the value desired. The minimum value is OFF; this shuts the set point off. The next increment is to 4.0 mTorr.

When the RAISE and LOWER buttons are pressed, the display will change slowly at first. If you hold the button down for a few seconds, the rate of change will increase to allow you to make large changes more quickly.

SET PT 1 HIGH operates in conjunction with SET PT 1 LOW. While the 926A is in this mode, the set point may be assigned to either GAGE 1 or GAGE 2 by pressing the GAUGE SELECT button.

### 2. Set Pt 1 low

This sets the low limit of the set point. This is the pressure at which the set point relay will be energized. Operation is similar to that of SET PT 1 HIGH above. The minimum value is OFF; this shuts the set point off. The next increment is to 3.0 mTorr.

*SET PT 1 LOW operates in conjunction with SET PT 1 HIGH.*

#### NOTE

The High and Low set point allow the user to set the hysteresis of the set point operation. As the system is pumped down, the set point relay will be energized (set point turns on) as the pressure drops below SET PT 1 LOW. The relay will remain energized until the pressure rises above SET PT 1 HIGH.

It is not possible to adjust the High set point to be lower than the Low set point. If you adjust the High set point below the pressure previously selected for the Low set point, the 926A will automatically reduce the value for the Low set point so that it is the next increment lower than that of the High set point.

### **3. Set Pt 2 High**

This operates in the same manner as SET PT 1 HIGH, described above.

### **4. Set Pt 2 Low**

This operates in the same manner as SET PT 1 LOW, described above.

### **5. Torr/mBar**

This allows selection of the units to be used in display of the pressure. Press either the RAISE or LOWER buttons to alternate between Torr and mBar. You will notice that both the GAGE 1 and GAGE 2 indicators will be lit also. This is to let you know that the units of measure apply to both gauges; it is not possible to select Torr for one gauge and mBar for the other gauge.

### **6. Setting Atmosphere**

You should know the local barometric pressure before proceeding; your local airport may have this information. Normal pressure is approximately 760 Torr (1000 mBar) at sea level.

Press the button labeled SELECT until the ATM LED is flashing. You may now use RAISE and LOWER to set the pressure to the desired pressure. Initially, the display may read a value which is substantially higher than atmospheric pressure, or even "HI". Just proceed to use the LOWER button to bring it into range. If you try to set ATM pressure when the pressure is less than approx. 200 torr (350 mBar), you will get a long beep from the loudspeaker. As the display changes, you will hear a series of 'chirps' from the loudspeaker.

### **7. Zero**

This allows the user to adjust the zero for each gauge. Before making this adjustment, the gauge should be connected to a vacuum system at a pressure lower than 0.1 mTorr. This adjustment may also be used to set the display to a specific value if you know the pressure through other means. For example, if the gauge to be adjusted is attached to a system that has another gauge which has been independently calibrated, the gauge may be made to read the same as the calibrated gauge. The ZERO function may be adjusted only when the gauge reading is lower than 50 mTorr. If you try to set zero pressure when the instrument is greater than 50 mTorr (65 mBar), you will get a long beep from the loudspeaker.



## 8. Gas Default Value: Air

On the next (6th) press of the SELECT button, you will be in the GAS SELECT mode. This allows selection of the gas response curve to be used for the Convection gauge.

The display will flash GAS, and the AIR/ARGON LED bars next to the Gage Select button will indicate the currently selected GAS.

Press either the RAISE or LOWER buttons to toggle between AIR or ARGON. The GAS choice applies to both gauges; it is not possible to select AIR for one gauge and ARGON for the other gauge.

The Convection tube response curve for Argon is different from Air by a constant factor below 1 Torr and departs dramatically at pressures above 1 Torr. When ARGON is chosen as the GAS, the response curve for argon is used to display the pressure more accurately.

## 9. Reset of Stored Values

This allows you to recover the factory settings for all stored values and resets the SET POINTS to off. For a system that is far out of calibration, the factory settings provide a good starting point for re-calibrating or adjusting the gauge controller. To recover the factory settings, unplug the 926A from its power source. Press and hold RAISE and LOWER buttons at the same time; while holding the RAISE and LOWER buttons depressed, plug the power cord in. You will hear a few short 'chirps' from the loudspeaker confirming the factory settings have been entered. The digital display will show RST to confirm the reset has been entered.

## D. Set Point Operation

See description of operation under **Front Panel Controls**.

## E. Reading Pressure

Pressure display and ranging are automatic in the 926A. Most readings will take place between zero pressure and the full scale of the 926A. For pressure lower than the minimum capability of the 926A, the display will show -LO. For pressure greater than the maximum full scale of the 926A, the display will show HI.

## F. Analog Output

The analog output is calculated from the value of the digital display. The output is logarithmic, 0.5 volt/decade; the source impedance for the output is 1 K ohm. The output voltage is calculated from:

$$V=0.50*(\log_{10}(100*Pressure))$$

where V is the Analog Output in volts; P is the pressure in mTorr or  $\mu$ bar.

Some examples follow; because of normal tolerances in the electronics, there may be minor differences in the values you observe compared to those shown:

<u>displayed pressure</u>	<u>Analog Output - volts</u>
<b>LO</b>	0.00
0 mTorr ( $\mu$ Bar) or less	0.00
0.10 mTorr ( $\mu$ Bar)	0.50
0.20 mTorr ( $\mu$ Bar)	0.65
1.0 mTorr ( $\mu$ Bar)	1.00
10.0 mTorr ( $\mu$ Bar)	1.50
100 mTorr ( $\mu$ Bar)	2.00
1.00 torr (mBar)	2.50
10.0 Torr ( $\mu$ Bar)	3.00
100 Torr (mBar)	3.50
999 Torr (mBar)	4.00
<b>OFF or HI</b>	4.00

**Figure 6: Analog Output versus Displayed Pressure**

The pressure as a function of the Analog Output voltage is:

$$P=0.01*\log^{-1}(2V)\text{or}$$

$$P=0.01*10^{(2V)}$$

where P is pressure in mTorr or  $\mu\text{bar}$ ; V is the Analog Output in volts.

<u>Analog Output - volts</u>	<u>pressure</u>
0.10	0.016 mTorr ( $\mu\text{bar}$ )
0.50	0.10 mTorr ( $\mu\text{bar}$ )
1.00	1.00 mTorr ( $\mu\text{bar}$ )
1.10	1.58 mTorr ( $\mu\text{bar}$ )
2.00	100 mTorr ( $\mu\text{bar}$ )
3.50	100 Torr (mBar)
4.00	1000 Torr ( $\mu\text{Bar}$ )

### **Figure 7: Pressure versus Analog Output**

**NOTE:**

The analog output is valid for the gauge which is selected on the display.

## G. Serial Interface

The RS-232 serial port gives pressure readings when requested by the terminal. The interface is standard RS-232 format; 9600 baud, 8-bits, no parity, 1 stop bit. The interface is through the 15-pin D-sub accessory connector, see fig. 2, page 6.

pin 7 is Tx (signal from the 926A to the terminal)  
 pin 8 is Rx (signal from the terminal to the 926A)  
 pin 9 is return (ground).

The serial port allows reading pressure and other parameters of the 926A; it is not possible to modify stored parameters over the serial port.

The following commands are used in the 926A:

### 1. Pressure

To read the pressure of both gauges

Send “p” (ASCII value 112); the 926A sends pressure for gauge 1 and gauge 2 to the terminal. Output is in the format:

*ABCeD      EFGeH*

where

*ABC* is the multiplier and *D* is the exponent for gauge #1

*EFG* is the multiplier and *H* is the exponent for gauge #2

Some examples follow:

<u>displayed pressure</u>	<u>Serial Output</u>
<b>OFF</b>	Off
<b>LO</b>	Low
0.0 mTorr	0.00e-3
0.8 mTorr	0.80e-3
2.8 mTorr	2.80e-3
-1.6 mTorr	-1.6e-3
57.1 mTorr	57.1e-3
2.34 torr	2.34e+0
135 torr	135e+0
<b>HI</b>	999e+0

**Figure 8: Serial Output Format versus Pressure**

Since both gauges are maintained in an active state, pressure data taken over the serial port are always valid for both gauges at the same time, regardless of which gauge is shown on the digital display.

## 2. Units Of Measurement

To read the chosen units of measure for both gauges

Send “u” (ASCII value 117); the 926A returns

**Torr**  
or  
**mBar**

## 3. Set Point #1

To read the setting and status of set point #1

Send “1” (ASCII value 49); the 926A returns information for set point #1 in the format:

***STUeV WXYeZ A B***

where

*STU* is the multiplier and *V* is the exponent for set point #1 high

*WXY* is the multiplier and *Z* is the exponent for set point #1 low

*A* is set point relay status; 0= relay is not energized, 1=relay is energized

*B* is the gauge to which the set point #1 has been assigned: either 1 or 2

## 4. Set Point #2

To read the setting and status of set point #2

Send “2” (ASCII value 50); the 926A returns information for set point #2 in the same format as for set point #1, above.

## 5. Model And Software Revision

To read software identification.

Send “v” (ASCII value 118); the 926A returns the model number of the instrument and the revision number, as in the following example:

**926 ver 1.02**

## 6. Reading Convection Gauge Type from RS-232 Port

To read the type of Convection Gauge Selected:

Send “x” ASCII value 120); the 926A returns the type of convection sensor tube selected, either HPS/MKS CEP or Granville Phillips 275 Convectron<sup>®</sup>, as in the following example:

**CEP or 275**

## 7. Reading Selected Gas (Air/Argon) Type from RS-232 Port

To read the type of Gas (Air/Argon) Selected:

Send “g” ASCII value 103); the 926A returns the type of gas selected, either Air or Argon, as in the following example:

**AIR** or **ARGON**

## 8. Other Gases

If you need to measure the pressure of gases other than air/nitrogen or argon, refer to the following table:

**Figure 9: Indicated pressure on Model 926A display, torr, ‘Air’ setting**

true pressure torr	CO2	Deuterium	Freon 12	Freon 22	Helium	Krypton	Methane	Neon	Oxygen
0	0	0	0	0	0	0	0	0	0
0.0001	0.0001	0.0001	0.0001	0.0001	0.0000	0.0000	0.0002	0.0001	0.0001
0.0002	0.0002	0.0002	0.0003	0.0002	0.0002	0.0002	0.0003	0.0001	0.0002
0.0005	0.0006	0.0006	0.0008	0.0007	0.0004	0.0003	0.0008	0.0003	0.0005
0.001	0.0011	0.0019	0.0015	0.0014	0.0008	0.0005	0.0018	0.0007	0.0010
0.002	0.0023	0.0024	0.0030	0.0029	0.0016	0.0010	0.0032	0.0014	0.0020
0.005	0.0055	0.0060	0.0075	0.0068	0.0040	0.0023	0.0077	0.0035	0.0049
0.01	0.0109	0.0120	0.0147	0.0135	0.0080	0.0046	0.0152	0.0070	0.0097
0.02	0.022	0.024	0.030	0.027	0.016	0.009	0.031	0.014	0.020
0.05	0.055	0.060	0.073	0.069	0.041	0.024	0.077	0.035	0.049
0.1	0.107	0.120	0.142	0.136	0.082	0.046	0.158	0.070	0.097
0.2	0.208	0.247	0.270	0.259	0.163	0.085	0.310	0.140	0.192
0.5	0.494	0.673	0.599	0.582	0.427	0.214	0.764	0.353	0.477
1	0.93	1.51	1.03	1.01	0.92	0.39	1.56	0.73	0.95
2	1.67	4.02	1.59	1.62	2.16	0.68	3.23	1.60	1.90
5	3.24	261	2.38	2.54	13.2	1.25	13.3	5.10	4.85
10	4.84		2.86	3.29		1.74	28.6	21.5	10.1
20	6.39		3.21	3.61		2.23	359	584	22.4
50	8.00		3.68	4.02		2.50	845		85.7
100	9.02		4.56	4.78		2.66			226
200	12.0		5.81	6.23		3.07			303
300	16.8		6.69	7.31		3.49			383
500	29.4		8.06	8.98		4.10			603
700	48.8		9.20	10.4		4.60			861
760	56.0		9.52	10.8		4.63			943
900	88.2		10.2	11.7					
1000	129		10.8	12.4					

These data were compiled from a variety of sources, and are believed to be reliable, however Dun-  
iway Stockroom Corp. takes no responsibility for errors in the data. If your application is critical,  
we suggest you use the services of an independent laboratory to calibrate the HPS/MKS 317 or  
CONVECTRON® gauge and Model 926A controller to your specific application.

## 9. RS-232 Communications guide for Terranova Model 926A

The RS-232 serial port allows reading pressure and other parameters when requested by the terminal; it is not possible to modify stored parameters, e.g. Set Points, over the serial port. The interface is standard RS-232 format; 9600 bps, 8-bits, no parity, 1 stop bit. The interface is through the 15-pin D-sub accessory connector on the back of Terranova 1/8 DIN products, except Model 809, which has no serial interface. The serial port is only active in Measurement Mode.

### Initial Preparation

#### a. Terminal Software

HyperTerminal software is installed on the Windows operating system for most PC computers. This is a suitable terminal software for serial communication with Terranova 1/8 DIN products. In the event you need to install software for terminal emulation, **HyperTerminal Private Edition** is a free application and may be downloaded here: [www.hilgraeve.com/hpe/download.html](http://www.hilgraeve.com/hpe/download.html)

#### b. Serial cable

The correct serial cable must be used. Please verify that your cable connections are as follows:

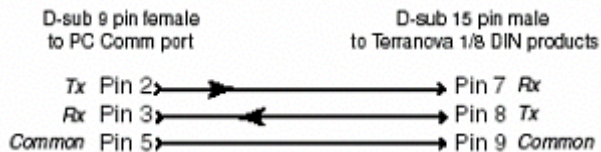

#### c. COM port selection

Make sure the PC end of the serial cable is connected to the COM port which is selected in the terminal software.

#### d. Sending and interpreting commands

The commands are a single character. There is no carriage return after the command character. The instrument returns "%Error" when an invalid (e.g. incorrect syntax) or unrecognized (e.g. wrong parity or baud rate) command is received.

## VI Maintenance

### A. Changing Fuses

The controller contains two fuses. Both fuses are held in the fuse assembly that is part of the power module located on the back panel of the controller. To change fuses, unplug the line cord from the power entry module at the rear of the 926A; locate the fuse block immediately below the line cord socket. Press the tab of the fuse assembly and withdraw the fuse assembly from the power module.

Turn the fuse assembly around so that the fuses are facing you. Check both fuses; replace the burnt-out fuse with a fuse of the appropriate rating (refer to **Specifications** section). Reinsert the fuse assembly into the power module; push it in until the ears click into place.

Replacement fuse type: 5 mm X 20 mm, regular 1 amp

<u>manufacturer</u>	<u>fuse type</u>
Bussman	GDB-1A or GDC-1A
Littlefuse	217 001 or 218 001

### B. Schematic Diagrams

Because of the proprietary nature of our products, we do not supply schematic diagrams or software listings. If you have any problem with operation or interface to any of our products, please contact us; we will do everything we can to serve your needs.



## VII Trouble Shooting

### 1. If the self-test fails:

run the self-test again by turning the power off and then on again. If it fails again, call Duniway Stockroom.

### 2. If fuses burn out:

check to see that the proper voltage has been supplied to the power input module.

If fuses burn out repeatedly call Duniway Stockroom.

If the display comes on dimly and does not indicate the correct pressure, check to see that the proper voltage has been selected on the power input module.

### 3. If pressure readings are unreliable or noisy:

Check the connection to the gauge tube. Check that the gauge tube is clean and not contaminated; a contaminated or dirty gauge tube can cause erratic readings. Use an ohmmeter to check that none of the CONVECTRON® gauge pins are shorted to the metal housing of the tube.

### 4. If readings at VAC or ATM seem wrong:

A new gauge is calibrated by the manufacturer to be within 5 mTorr of true zero at vacuum, and within 20 torr at 760 torr. If recovery of factory settings (see **Operation** section) does not give readings which appear reasonable, it is possible that your gauge has become contaminated or damaged. You may try cleaning the gauge using acetone or TCE (1-1-1 trichloroethane). Be careful when using flammable solvents, so that you do not risk explosion from the flammable vapors.

### 5. Resistance Reading for the CONVECTRON® Sensor Tube

You can measure the CONVECTRON® gauge to see if it has the correct internal resistance values. If the measured values differ from those shown, it is possible that your gauge has become damaged. These measurements must be made while the gauge is at atmospheric pressure; do not use a method which applies more than 10 mA to the pins or you will damage the fine internal wires.

<u>between pins</u>	<u>resistance</u>
1 and 2	20 ohm to 30 ohm
2 and 3	50 ohm to 60 ohm
1 and 5	175 ohm to 190 ohm

If the resistance between pins 1 and 2 measures approx. 800 ohms, it means the internal sensor wire is broken and the CONVECTRON® gauge must be replaced.

## 6. Resistance Reading for CEP Sensor Tube

Looking at the connector end of the gauge tube, you will see a male 9 pin D connector. (See diagram below). It will have 5 pins in one row and 4 pins in the other row. With the 5 pin row on top, pin #1 is on the left side of the top row and pin #6 is on the left side of the bottom row. These measurements must be made while the gauge is at atmospheric pressure: do not use a method which applies more than 10 mA to the pins or you will damage the fine internal wires.

For a good tube, the following are the approximate resistances, pin to pin:

<u>Between Pins:</u>	<u>Resistance</u>
Pin 1 to Pin 7	20 ohms
Pin 1 to Pin 8	200 ohms
Pin 5 to Pin 7	48 ohms

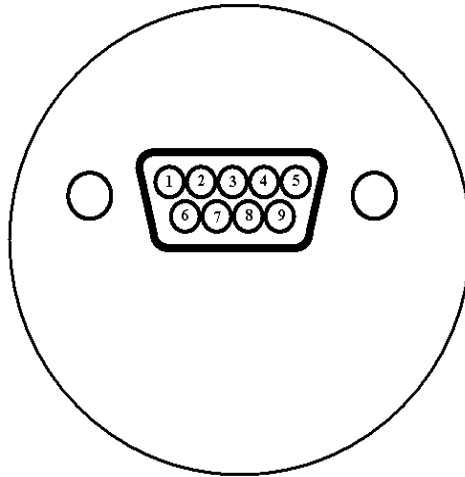

**Figure 10: MKS/HPS Model 317 CEP  
(end view)**

## **VIII Return Procedure**

If you need to return the gauge controller for service, first contact Duniway Stockroom to get authorization. Then pack the instrument securely. Use the original packaging if it is available. If you do not have appropriate packing materials, a commercial packing and shipping firm can provide them.

## IX Warranty

*Terranova products of Duniway Stockroom Corp. are warranted to be free of defects in material and workmanship for a period of one year from the date of shipment. At our option, we will repair or replace products which prove to be defective during the warranty period. Liability under this warranty is limited to repair or replacement of the defective items. Shipping damage is excluded from the scope of this warranty. Gauge tubes of all types are excluded from this warranty.*

*Terranova products are warranted not to fail to execute programming instructions due to defects in materials and workmanship. If Duniway Stockroom receives notice of such defects during the warranty period, Duniway Stockroom will repair or replace firmware that does not execute its programming instruction due to such defects. Duniway Stockroom does not warrant that the operation of the firmware or hardware will be uninterrupted or error-free.*

*If this product is returned to Duniway Stockroom for warranty service, Buyer will pre-pay shipping charges and will pay all duties and taxes for products returned to Duniway Stockroom. Duniway Stockroom will pay for return of products to Buyer, except for products returned to a Buyer from a country other than the United States.*

*LIMITATION OF WARRANTY: The foregoing warranty does not apply to the defects resulting from:*

- 1. Improper or inadequate maintenance by Buyer;*
- 2. Buyer-supplied interfacing;*
- 3. Unauthorized modification or misuse;*
- 4. Operation outside of the environmental specifications of the product; or*
- 5. Improper site preparation and maintenance.*

*THE WARRANTY SET FORTH ABOVE IS EXCLUSIVE AND NO OTHER WARRANTY, WHETHER WRITTEN OR ORAL, IS EXPRESSED OR IMPLIED. DUNIWAY STOCKROOM DISCLAIMS ANY IMPLIED WARRANTIES OF MERCHANTABILITY AND FITNESS FOR A PARTICULAR PURPOSE.*

*EXCLUSIVE REMEDIES: The remedies provided herein are Buyer's sole and exclusive remedies. In no event will Duniway Stockroom be liable for direct, indirect, special, incidental, or consequential damages, including loss of profits, whether based on contract, tort, or any other legal theory.*

## X DECLARATION OF CONFORMITY

---

**We, Duniway Stockroom Corp., declare under our sole responsibility,  
that the following products, displaying the CE mark on the rear panel:**

Model 906A Convection Gauge Controller  
Model 926A Dual Convection Gauge Controller  
Model 908A Dual Capacitance Gauge Controller

**to which this declaration relates, are in conformity with the following  
standards or normal documents**

EMC Directive (89/336/EEC//93/68/EEC)  
Electromagnetic Compatibility  
Standards: EN 50081-1: 1992, EN 50082-1: 1993



Low Voltage Directive (73/23/EEC//93/68/EEC  
)Electrical/Technical Safety  
Standard: EN 61010-1: 1993/A2: 1995

**following the provisions of the EMC directive (89/336/EEC)**

-----  
Safety of Electrical Equipment for Laboratory Work  
UL3101-1, 1st Edition  
CAN/CSA C22.2 No. 1010.1-92



May 22, 2002

**by: Sherman Rutherford**  
Compliance Manager

Duniway Stockroom Corp.  
1305 Space Park Way  
Mountain View, California 94043

rev071404sr